

Level the mount and mark.

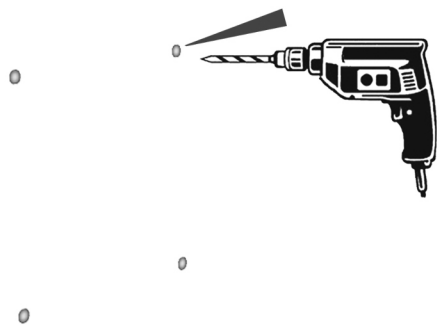

Drill the mounting holes.

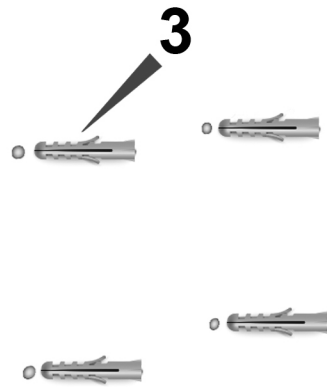

Insert the wall anchors* to the wall and tap them flush with a hammer.
* Never use wall anchors on drywall

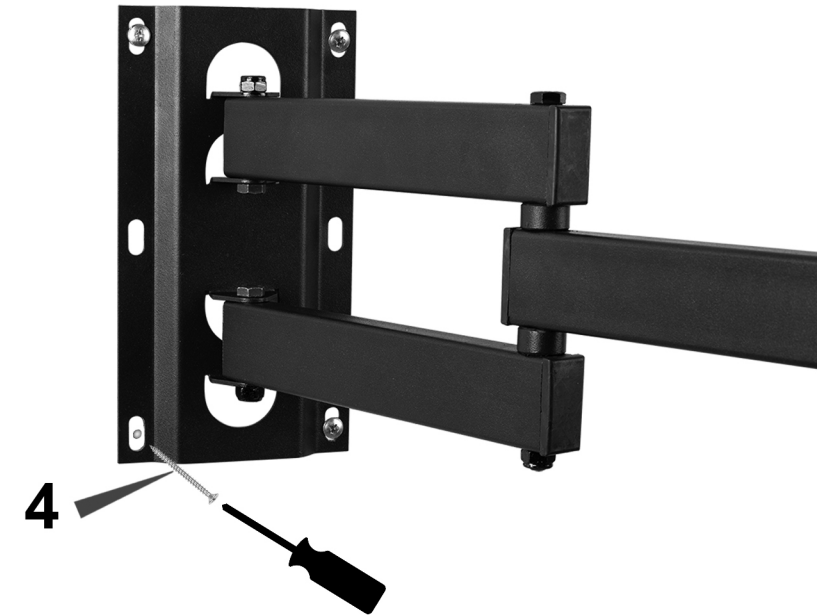

Fix the plate to the wall.

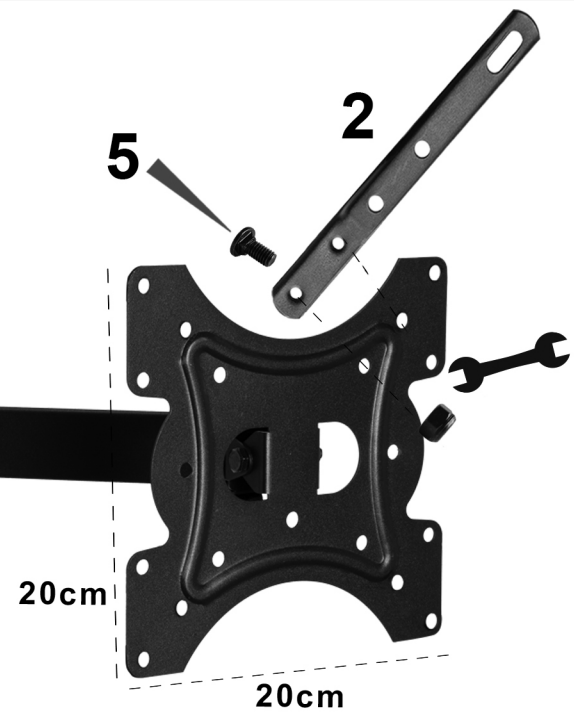

Attach arms to the body if needed.

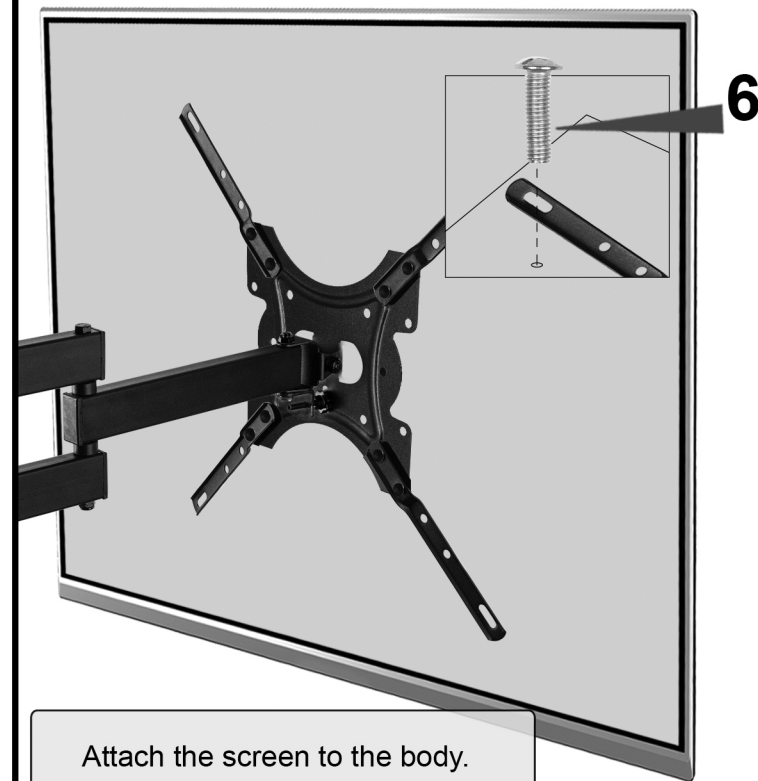

Attach the screen to the body.

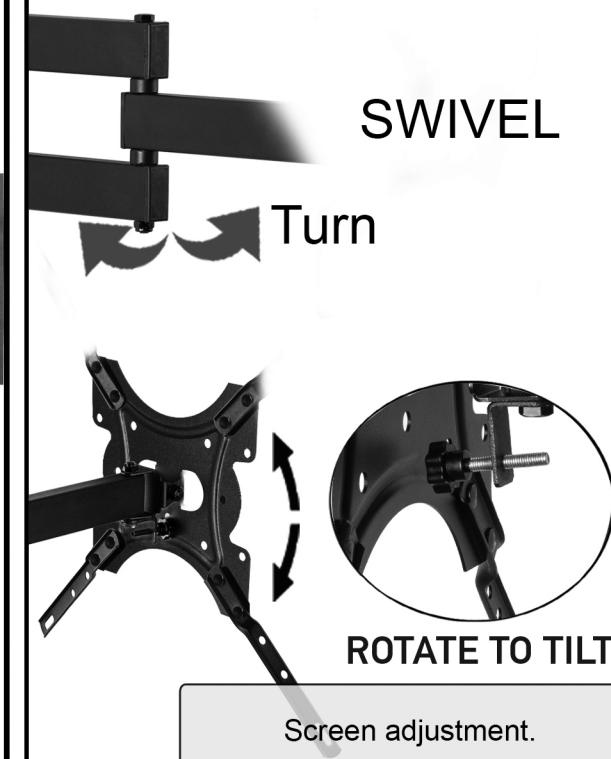
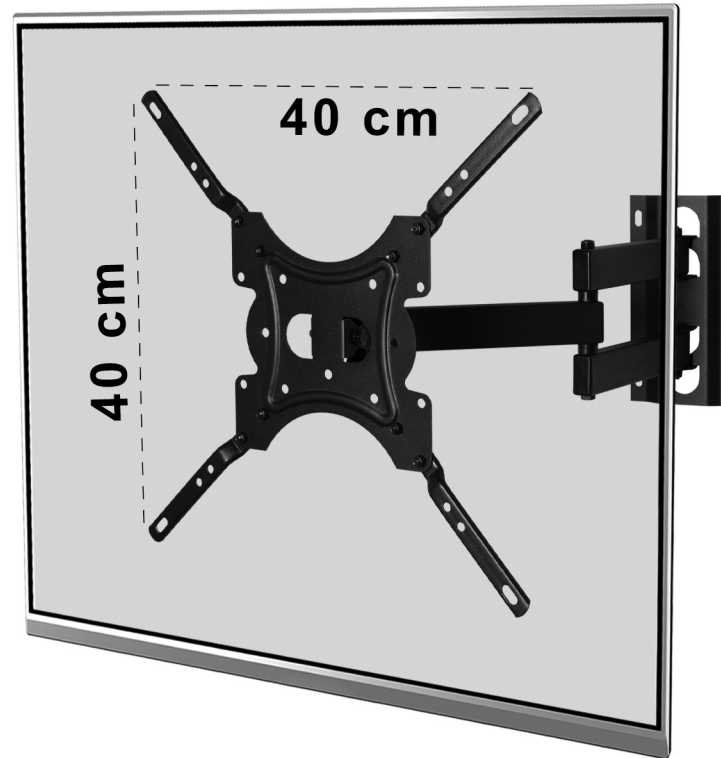

Screen adjustment.

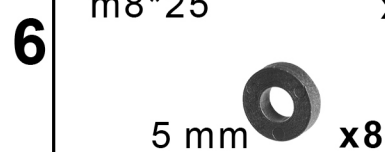
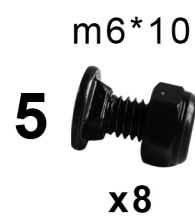
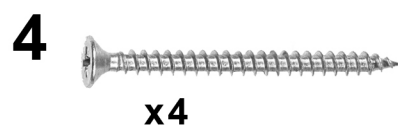
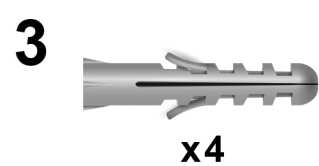
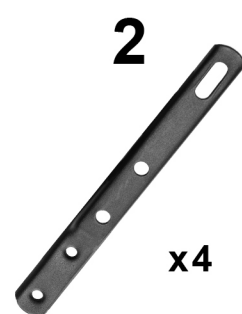
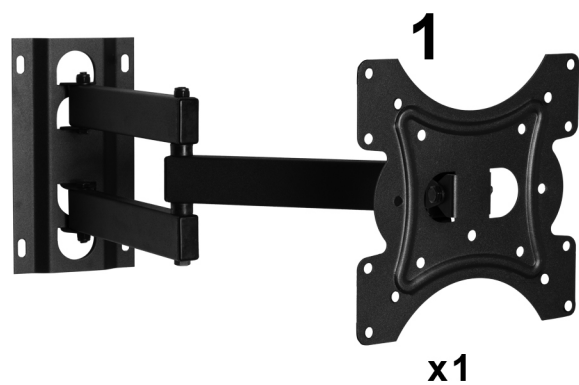

m6*15 x4

m8*25 x4

5 mm x8

Note :

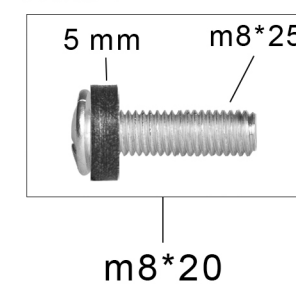

IF NEEDED

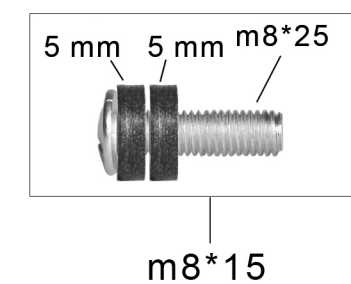

m8*15

SONOROUS

REV. NO.: 05 / 27.03.2024