



## Extras - Mounting series

Secure, easy operation

CTOUCH offers you a perfect fit if you need a flexible mounting solution. The Wallom2 mobile lift has an unique and enhanced design with high demands of ergonomics, quality and durability. The lift is easy to maneuver without becoming unstable due to the big and solid TENTE<sup>®</sup> wheels and a push rod. Easy to install and operate.

### Easy to use:

- ✓ Remote with 3 buttons to set your own personalized height preference
- ✓ Smart phone app for secured Bluetooth control (option)
- ✓ Robust design for a comfortable and stable ride. Big wheels by Tente<sup>®</sup> of Ø 60 mm.

### Easy to install:

- ✓ The lift comes pre-assembled in ONE box and can be installed by one person in < 20 minutes
- ✓ Suits CTOUCH display sizes from 55" to 86"
- ✓ Maximize your reach height. From as low as 30 cm (bottom side of 86" display) to as high as 245 cm (top side 86" display)

### Durable and secure:

- ✓ Dutch design and solid Danish Linak<sup>®</sup> lift engineering
- ✓ Anti-collision module to prevent people and objects from unintended contact with the lift (option)
- ✓ 5 years warranty

**Product number**

- Wallom2 mobile lift - Black (RAL 9005) 10080251
- Flexible and easy maneuverable lift solution for CTOUCH displays

**Mounting system**

- Electrical lift system by Linak<sup>®</sup>
- Floor stand: 4 TENTE wheels, 2 with brake
- Colour lift: Aluminium, black
- Max. weight: 150 kg
- Mains voltage 100 - 240V AC, 50Hz - 60Hz (universal)

**Features**

- Height adjustment: Electrical
- Control panel: Up and down
- 3 programmable buttons to set your personalized working height
- Lift speed: 15 mm/s - From bottom to top in 25 sec.
- Lockable storage space on the backside: 150 mm (D) x 190 mm (W) x 240 mm (H)
- Vesa dimensions: 400 mm (W) x 400 mm (H) 600 mm (W) x 400 mm (H)

**Optional accessories**

- Extension bracket to higher or lower the display by an extra 230 mm (see nr. 1) 10080256
- Push rod for easy maneuvering (see nr. 2) 10080255
- Notebook / tablet high shelf: 400 mm (L) x 300 mm (W), max 5 kg (see nr. 5) 10080261
- Bottom plate for desktop pc: 400 mm (L) x 200 mm (D) x 450 mm (H), max 5 kg (see fig. 3) 10080258
- Pen tray : 50 mm (D) x 500 mm (W) (see nr. 4) 10080257
- Anti collision module 10080264

**Warranty**

- 5 years warranty based on carry-in (limited warranty on wheels)

**Logistic dimensions**

- Box size (mm): 1200 (W) x 700 (D) x 320 (H) - 50 kg
- EAN 8719481480011

**About the Wallom2 lift**

The Wallom2 owns a high quality solid lift system with a linear actuator of LINAK<sup>®</sup>.

- Smooth and soundless lift system
- Robust and strong design
- Lifetime lift (cycle up & down): 10.000

**About the Wallom2 castors:**

CTOUCH knows that if you choose a mobile lift it should be easy to maneuver the unit. Therefore we chose the state-of-the-art brand castors from TENTE<sup>®</sup>, one of the world's best manufacturers wheels and castors. The swivel castors, of which two have a wheel brake:

- Are made of high quality synthetic material
- Turns & rolls smoothly, almost soundless
- Leaves no marks while moving
- Are corrosion protected, for a long life span



# Optional accessories

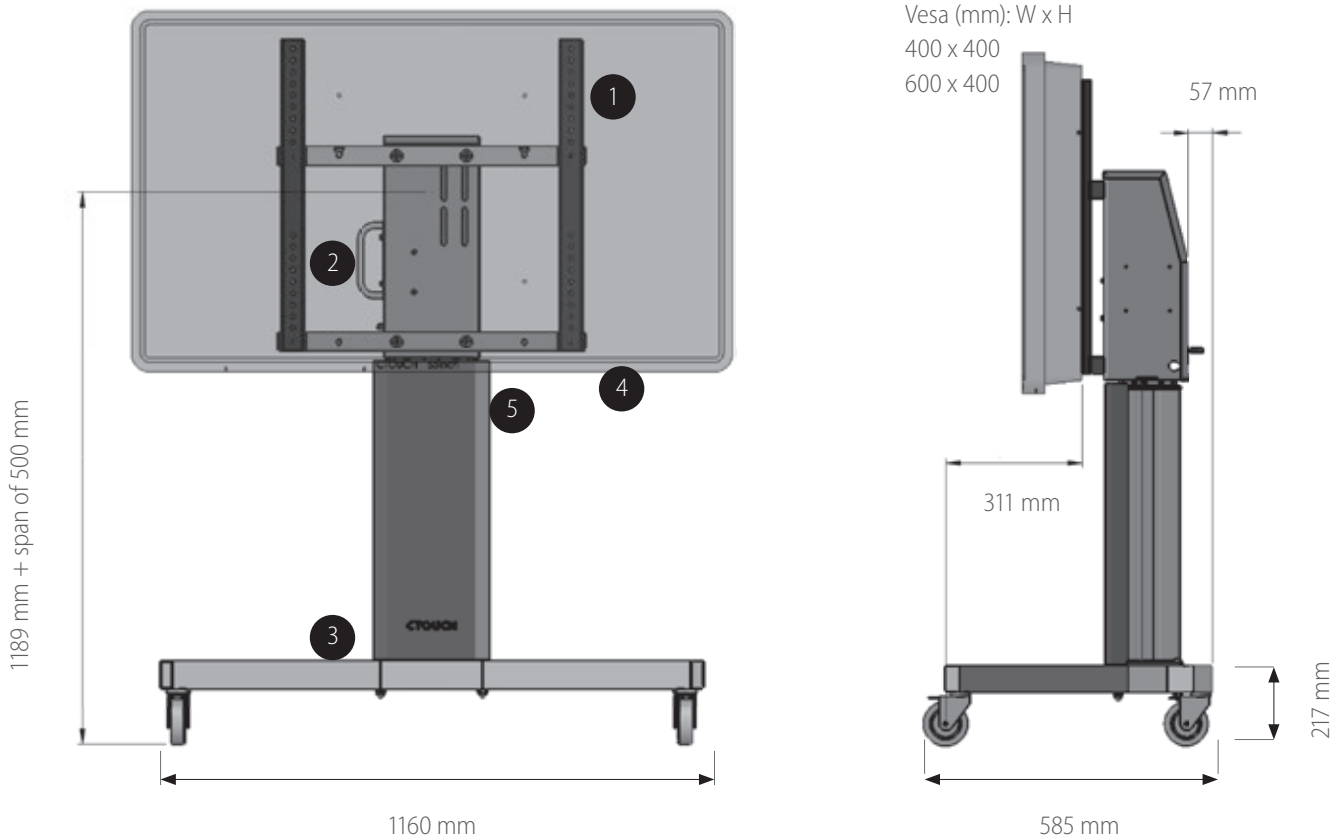

**Display configurations**

Wallom2 mobile lift height positions with: Laser air+, Leddura 2Share & Leddura 2Meet (in mm):

	Default bracket		With optional extension bracket	
	bottom display in lowest position	top display in highest position	bottom display in lowest position	top display in highest position*
55 INCH	704	1985	474	2215
65 INCH	650	2052	420	2282
70 INCH	713	2181	483	2411
75 INCH	591	2119	361	2349
86 INCH	537	2215	307	2445

\* = Safety tests pending

No rights can be derived from this data sheet. Product specifications and data of this product are subject to change without notice to improve reliability, function, design or otherwise.

All rights reserved. CTOUCH products and services mentioned herein as well as their respective logos are trademarks or registered trademarks of CTOUCH Europe B.V.. All other product and service names mentioned are the trademarks of their respective owners.