

**KL-650-THX  
KL-525-THX  
KS-525-THX  
KW-120-THX**

**LOUDSPEAKERS**

**OWNER'S MANUAL**



# THX ULTRA2 LOUDSPEAKERS

## IMPORTANT SAFETY INSTRUCTIONS

1. READ these instructions.
2. KEEP these instructions.
3. HEED all warnings.
4. FOLLOW all instructions.
5. DO NOT use this apparatus near water.
6. CLEAN ONLY with dry cloth.
7. DO NOT block any ventilation openings. Install in accordance with the manufacturer's instructions.
8. DO NOT install near any heat sources such as radiators, heat registers, stoves, or other apparatus (including amplifiers) that produce heat.
9. DO NOT defeat the safety purpose of the polarized or grounding type plug. A polarized plug has two blades with one wider than the other. A grounding type plug has two blades and a third grounding prong. The wider blade or the third prong are provided for your safety. If the provided plug does not fit into your outlet, consult an electrician for replacement of the obsolete outlet.
10. PROTECT the power cord from being walked on or pinched, particularly at plugs, convenience receptacles, and the point where they exit from the apparatus.
11. ONLY USE attachments/accessories specified by the manufacturer.
12. USE only with a cart, stand, tripod, bracket, or table specified by the manufacturer, or sold with the apparatus. When a cart is used, use caution when moving the cart/apparatus combination to avoid injury from tip-over.
13. UNPLUG this apparatus during lightning storms or when unused for long periods of time.
14. REFER all servicing to qualified service personnel. Servicing is required when the apparatus has been damaged in any way, such as power-supply cord or plug is damaged, liquid has been spilled or objects have fallen into the apparatus, the apparatus has been exposed to rain or moisture, does not operate normally, or has been dropped.



 This symbol indicates that there are important operating and maintenance instructions in the literature accompanying this unit.



This symbol indicates that dangerous voltage constituting a risk of electric shock is present within this unit.

**WARNING:** To reduce the risk of fire or electrical shock, do not expose this apparatus to rain or moisture.



**WARNING:** Voltages in this equipment are hazardous to life. No user-serviceable parts inside. Refer all servicing to qualified service personnel.

**CAUTION:** Changes or modifications not expressly approved by the manufacturer could void the user's authority to operate this device.

## ABOUT YOUR KLIPSCH PURCHASE

Thank you for your purchase of Klipsch THX® Ultra2™ loudspeakers. After reading this manual and connecting your system, you will hear the results of over 55 years of stringent engineering and class-leading research and development. Like all Klipsch products, your loudspeakers feature Klipsch Tractrix® Horn-loaded Technology— the guiding design for the first Klipschorn® developed in 1946 and for every product that has followed. Horn-loading allows your speakers to deliver high sensitivity, low distortion, flat frequency response and wide dispersion, which translates to unequalled power, detail, and dynamics, the hallmark of "The Klipsch Sound." Please be sure to fill out the warranty card at the back of this manual or online at [www.klipsch.com](http://www.klipsch.com) so we are better able to serve you. Again, thank you for choosing Klipsch and we hope that your speakers bring life to your music and movies for many years.

## UNPACKING

The easiest way to remove the speaker from its carton is to turn the open end of the box down so that it is resting on a table or the floor, with the flaps spread out and away. Then pull the box straight up and off. Remove any packing material from the speaker and grille, place it back in the carton, and store in case you ever need to ship the loudspeaker. Each speaker comes supplied with rubber stick-on feet that should be applied to prevent any damage to either the speaker or the surface on which it is resting. (See Figure 1.)

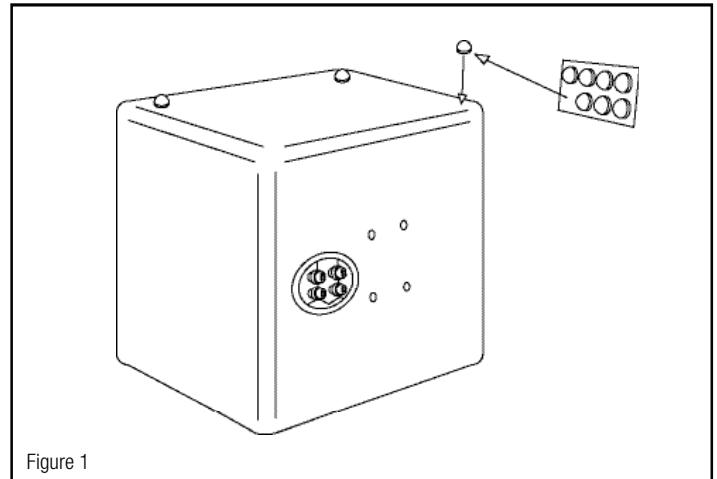

Figure 1

## PLACEMENT

Your THX Ultra2 loudspeakers will achieve optimum performance when located in conformance with THX guidelines, on which the following instructions are based. Don't be discouraged if some compromise is necessary, however, or if modest adjustments will make the system look much better in the room. The speakers are engineered to deliver excellent sound over a relatively wide range of placements within the basic framework of a 5.1-, 6.1-, or 7.1-channel surround-sound installation. This is especially the case for WDST™ (Wide Dispersion Surround Technology) surround speakers, which offer many more practical placement options than conventional designs. In the end, all that matters is what sounds good to you and what works in your home theater.

Before we move on to the specifics, here are some placement considerations that apply universally.

### General Rules

- Front speakers typically sound best when their tweeters are at approximately ear height for seated listeners. If this isn't possible (as it often is not for center-channel speakers), it is sometimes beneficial to tilt the speaker slightly so that it is aimed into the listening area. Surround-channel speakers usually perform best when placed slightly above seated ear level.
- If you are putting speakers in a cabinet, try to bring their fronts out far enough that they are at least flush with the cabinet's front.
- When practical, arrange each speaker so that its woofer is at somewhat different distances from the floor, the wall behind it, and the wall beside it. It can also help to have the left and right front speakers at different distances from their nearest side walls. This sort of staggering helps smooth the bass range.
- Any speaker's bass output and response is strongly influenced by its distance from room boundaries, such as walls and the floor. Moving a speaker closer to a room boundary will increase its bass output, while moving it away will reduce the bass. So you will get maximum bass from a speaker by placing it in a corner and minimum bass by placing it in the center of the room.

### System Configuration

Figure 2 shows a THX-Ultra2 compliant 7.1-channel speaker layout. (Configuration for 5.1 channels is the same minus the surround back loudspeakers behind the listening area.) KL-650-THX or KL-525-THX LCR's are used for front left, center, and right channels. The left and right surrounds are KS-525-THX WDST™ loudspeakers. The surround back speakers are narrowly spaced KL-650-THX or KL-525-THX LCR's. In some installations, it may be preferable to use KS-525-THX's for the surround back channels due to their smaller size. Their WDST design works very well in this application. Two KW-120-THX subwoofers are necessary to achieve THX Ultra2 maximum output requirements. This specification assumes a very large room, however, and in many installations a single

KW-120-THX will be completely adequate. The companion KA-1000-THX subwoofer amplifier can drive either one or two subwoofers. In dual-subwoofer systems, it is usually best to place them right next to each other rather than spaced apart.

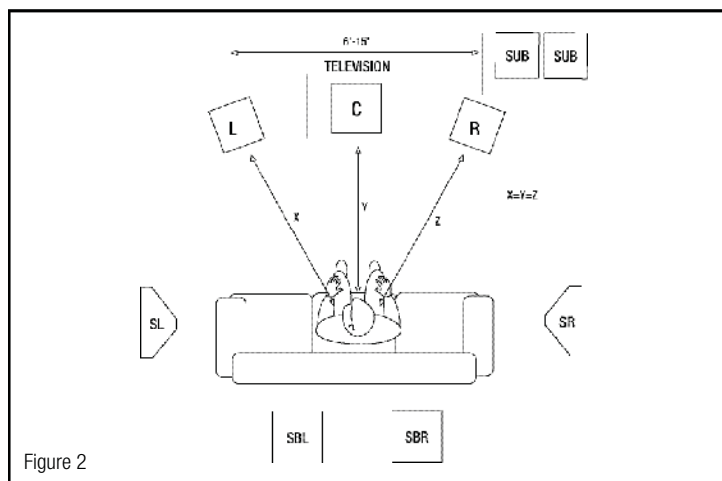

Figure 2

### Front LCR Loudspeakers

Normally the array would be either all KL-650-THXs or all KL-525-THXs, but the center speaker can be different from the left and right speakers. (For example, you might combine a pair of KL-650-THXs for the front left and right with a KL-525-THX for the center.) The center-channel speaker should be centered along the width of the TV screen, directly above or below it or, in the case of an acoustically transparent front-projection screen, behind it. The left and right speakers should be placed equal distances out from the edges of the TV screen. Exactly how far out depends on the size of the screen. A reasonable starting point is to place the left and right speakers so that they and your listening position form an equilateral triangle. Since the center speaker helps anchor the sound to the screen, it usually is better to have the left and right speakers spread a little too wide than to have them too close together. The left and right speakers should be aimed inward towards the listening position as shown in figure 2. In some installations, it may be desirable to wall-mount the front LCR speakers rather than to put them on stands or in a cabinet. To accommodate this, the KL-650-THX and KL-525-THX are both configured for use with OmniMount® 60.0 Series wall- and ceiling-mount brackets (See Figure 3). Refer to the OmniMount manual for detailed installation instructions.

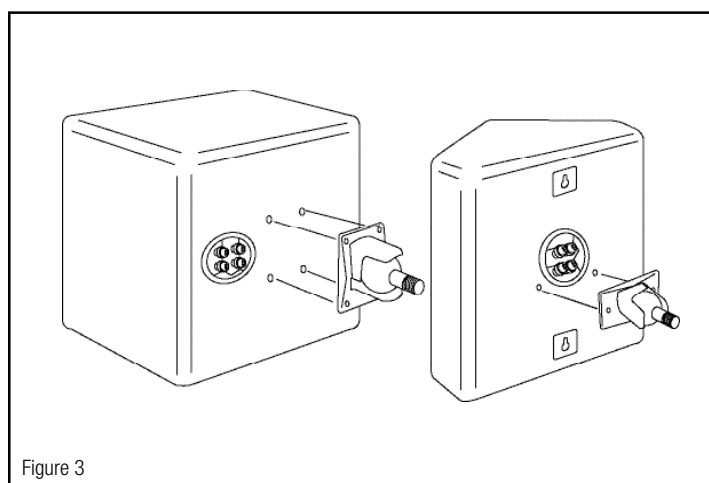

Figure 3

### Surround Left and Right Loudspeakers

In a 5.1- or 7.1-channel installation the left and right surround speakers will be KS-525-THX's placed to the sides of the listening area, typically on or against the walls. They should be elevated slightly above seated ear level – five or six feet above the floor is a good target. If desired, the speakers can be moved back along the wall to as much as 20 degrees behind the listening position, especially in a 5.1-channel system. The KS-525-THX's Wide Dispersion Surround Technology design gives you a great deal more latitude if you need it, delivering good results in configurations that depart significantly from the ideal. The KS-525-THX has a keyhole mount for use in hanging the speaker on the wall. To use the keyhole, all you need is a screw or nail of the appropriate size protruding slightly from the wall. If possible, the nail or screw should be driven into a wall stud; if not, be sure to use appropriate anchors in the dry-wall or plaster. Additionally, the KS-525-THX is configured for use with OmniMount® 20.0 Series wall- and ceiling-mount brackets (See Figure 3). Refer to the OmniMount manual for detailed installation instructions.

### Surround Back Loudspeakers

In addition to the left and right surrounds, THX Ultra2 7.1-channel system specifications call for two forward-radiating surround back loudspeakers behind the listening area, preferably spaced no more than a few feet apart. These would be KL-650-THX or KL-525-THX LCR's, either placed on stands, or ideally mounted on the back wall. Like the left and right surrounds, they should be slightly above seated ear level – about five to six feet off of the floor. In some installations, it may be preferable to use KS-525-THX's for the surround back channels due to their smaller size. Their WDST design works very well in this application. You will probably want to space the KS-525-THX surround back pair somewhat farther apart than you would the LCR's.

### Subwoofers

Two KW-120-THX subwoofers and a KA-1000-THX amplifier are required to meet THX Ultra2 maximum output requirements. This specification assumes a very large room, however, and in many installations a single KW-120-THX will be completely adequate. Although the KW-120-THX will perform well in a wide variety of locations, you will get the most out of it by following some simple guidelines:

- Although the subwoofer's orientation is not at all critical, avoid placing the front (driver) side of the cabinet up against a wall.
- The subwoofer's output will increase as it is moved closer to walls, with maximum output when it is placed in a corner. If practical, always place the subwoofer against or near a wall.
- In most rooms, a subwoofer will deliver smoothest bass response when placed in a corner away from room openings, such as doors. So if possible, that's the place to start.
- If you are using more than one subwoofer, you usually will get best performance by placing them together in the same location rather than by spacing them apart. Naturally, there are exceptions to the general rules, since no two rooms or systems are exactly alike. Once you have the subwoofer connected to your system and adjusted at least roughly (see the KA-1000-THX manual for details), you may want to experiment to see if you can do better.

## CONNECTIONS

**Note: Proper connection of your speakers to your amplifier or receiver is vital to obtaining good sound quality. Please follow these directions carefully. Sloppy connections can cause amplifier malfunction or damage.**

Klipsch THX Ultra2 loudspeakers are internally wired with custom Monster Cable® Z-Series speaker wire. Its Frequency Specific™ design employs multiple gauges of high-purity copper wire, carefully selected and wound to ensure optimum signal transfer at all frequencies. You will obtain best performance from your speakers if you connect them to your amplifier or receiver with Monster Cable or similar high quality wire available from your dealer. (The KW-120-THX comes with a 20-foot length of Monster THX Ultra-certified 1000 Series speaker cable terminated in professional-grade Neutrik® NL2 Speakon® connectors that mate with the jacks on the subwoofer and the companion KA-1000-THX amplifier.) At minimum, we recommend that you use 16-gauge or heavier stranded copper wire. Use lower-gauge (heavier) wire for long runs to maintain correct frequency response and minimize power loss.

On the back of each KL-650-THX, KL-525-THX and KS-525-THX speaker are two sets of binding posts, one feeding the tweeter and the other the woofers. For conventional wiring, these sets are connected together with gold-plated metal straps, which can be removed for bi-wiring or biamping. We will explain ordinary single-wiring first and then the alternatives. All the information regarding single-wiring also applies to bi-wiring.

## BUT FIRST: TYPES OF CONNECTORS

**Bare wire.** Pull the two conductors apart for about an inch and strip approximately 1/4-inch of insulation from the end of each. (A wire stripper will simplify this, but you can use an ordinary pocket knife to cut around and through the insulation down to the wire.) Twist the strands of wire on each individual conductor tightly together. Loosen the nuts on a pair of binding posts until the holes through the metal posts are exposed, then insert the bare wire through the holes. Screw the nuts down finger-tight on the wire. Make sure that no strands of wire are touching from one binding post to the other or to any strands from the other conductor. Failure to observe this precaution at either end of the connection can result in amplifier malfunction or damage.

**Pins.** Many pre-made speaker cables are terminated with metal pins. Loosen the nuts on a pair of binding posts until the holes through the metal posts are exposed, then insert the pins through the holes. Screw the nuts down finger-tight on the pins — do not overtighten.

# THX ULTRA2 LOUDSPEAKERS

Make sure that there is no metal-to-metal contact between the two pins or binding posts. Failure to observe this precaution at either end of the connection can result in amplifier malfunction or damage.

**Spade lugs.** Some speaker cables are terminated with U-shaped connectors called spade lugs. Loosen the nuts on a pair of binding posts and slip the spade lugs around the metal posts. Screw the nuts down finger-tight on the lugs and inspect to ensure they have remained firmly in place. Make sure that there is no metal-to-metal contact between the two lugs or binding posts. Failure to observe this precaution at either end of the connection can result in amplifier malfunction or damage.

**Other types of specialty connectors are available to facilitate hooking up your speakers. Please consult your authorized Klipsch dealer for suggestions and further details.**

## SPEAKERS TO AMPLIFIER: KEEPING IT STRAIGHT

One of the most important things about hooking up your speakers is keeping them in the same polarity, or phase. If they are connected out of phase, bass and sound imaging will be degraded.

The easiest way to ensure that your speakers are wired in phase is to always connect the positive and negative output terminals on your amplifier or receiver to the matching input terminals on your speakers: positive (“+,” color-coded red) to positive and negative (“-,” color-coded black) to negative. (See Figure 4.)

Most pre-made speaker cables have color-coded connectors that make it easy to match output and inputs correctly. If yours do not, or if you are making your own out of paired, two-conductor wire, look for identifying marks on the insulation of the two conductors. Normally there will be printing, a stripe or a molded ridge along one of the conductors.

**Bi-wiring** - In bi-wiring, separate cables are connected from the amplifier or receiver output terminals to the speaker input terminals for the tweeter and woofers (See Figure 5.) This results in lower electrical resistance between the amplifier and speaker than single-wiring with the same gauge cable. In some cases bi-wiring may be preferable to single-wiring with lower-gauge cable, which will be thicker and probably less flexible.

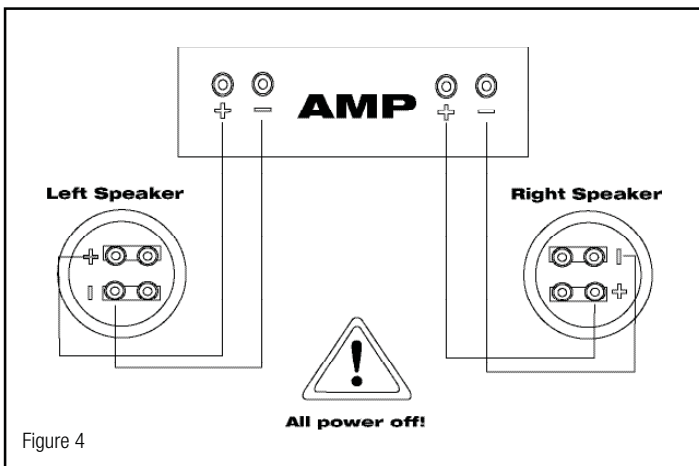

To bi-wire your THX Ultra2 speakers, loosen the nuts on the binding posts and remove the metal straps linking the woofer and tweeter terminals. Observing proper polarity, connect one cable to the tweeter binding posts and another to the woofer binding posts. Run both cables back to your amplifier or receiver and attach them to the same channel. (Do not, for example, attach one to an A speaker output and the other to a B speaker output on an amplifier or receiver with A/B speaker switching.) Amplifiers may be severely damaged if straps are not removed.

**Biamping** - In biampification, the tweeter and woofers are driven by separate amplifiers fed from the same preamplifier output. We do not recommend biampifying any of our speakers, since in general it will produce no benefit that could not be obtained simply by using a single larger amplifier and may cause severe sound degradation if not done properly. If you

do biampify, use the same model amplifier for the tweeter and woofer sections (to prevent frequency-response errors caused by different amplifier gains) and be sure to remove the straps linking the two sets of input terminals on the speaker. Amplifiers may be severely damaged if straps are not removed.

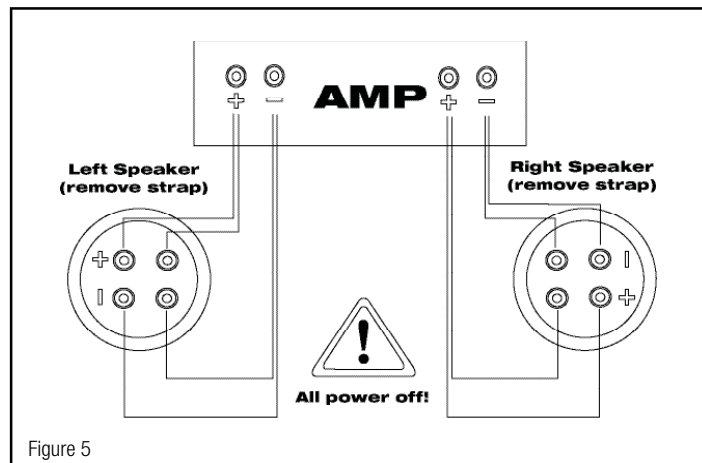

## BASS MANAGEMENT SETTINGS

Surround-sound receivers and processors use what is known as bass management to ensure that low frequencies in the various channels are sent to speakers that can handle them well and away from small speakers that cannot. Klipsch THX Ultra2 loudspeakers are optimized for the THX crossover setting. (Technically, that's an 80Hz crossover with a 12dB/octave high-pass section feeding the amplifiers for the satellite speakers and a 24dB/octave low-pass section feeding the subwoofer amplifier.) All THX-certified receivers and processors incorporate this crossover in their bass-management systems. Non-THX surround-sound components usually have crossovers somewhere from 80 to 100Hz and with slopes of 12 to 24dB/octave. Although the THX crossover is ideal for Klipsch THX Ultra2 speakers, these other crossovers will usually give acceptable results. Regardless, all Klipsch THX Ultra2 LCR and surround loudspeakers should be set to “Small” in your receiver or processor’s speaker setup menu.

## CARE AND CLEANING

The only thing you should ever need to do to your speakers is dust them occasionally. Never apply any abrasive or solvent-based cleaner or any harsh detergent. You can clean the grilles with the brush attachment of a vacuum cleaner.

## WARRANTY - U.S. AND CANADA

The Warranty below is valid only for sales to consumers in the United States or Canada. KLIPSCH, L.L.C. (“KLIPSCH”) warrants this product to be free from defects in materials and workmanship (subject to the terms set forth below) for a period of five (5) years from the date of purchase. During the Warranty period, KLIPSCH will repair or replace (at KLIPSCH’s option) this product or any defective parts (excluding electronics and amplifiers). For products that have electronics or amplifiers, the Warranty on those parts is for a period of two (2) years from the date of purchase.

To obtain Warranty service, please contact the KLIPSCH authorized dealer from which you purchased this product. If your dealer is not equipped to perform the repair of your KLIPSCH product, it can be returned, freight paid, to KLIPSCH for repair. Please call KLIPSCH at 1-800-KLIPSCH for instructions. You will need to ship this product in either its original packaging or packaging affording an equal degree of protection.

Proof of purchase in the form of a bill of sale or receipted invoice, which is evidence that this product is within the Warranty period, must be presented or included to obtain Warranty service.

This Warranty is invalid if (a) the factory-applied serial number has been altered or removed from this product or (b) this product was not purchased from a KLIPSCH authorized dealer. You may call 1-800-KLIPSCH to confirm that you have an unaltered serial number and/or you purchased from a KLIPSCH authorized dealer.



This Warranty is only valid for the original purchaser and will automatically terminate prior to expiration if this product is sold or otherwise transferred to another party.

This Warranty does not cover cosmetic damage or damage due to misuse, abuse, negligence, acts of God, accident, commercial use or modification of, or to any part of, the product. This Warranty does not cover damage due to improper operation, maintenance or installation, or attempted repair by anyone other than KLIPSCH or a KLIPSCH dealer which is authorized to do KLIPSCH warranty work. Any unauthorized repairs will void this Warranty. This Warranty does not cover product sold AS IS or WITH ALL FAULTS.

REPAIRS OR REPLACEMENTS AS PROVIDED UNDER THIS WARRANTY ARE THE EXCLUSIVE REMEDY OF THE CONSUMER. KLIPSCH SHALL NOT BE LIABLE FOR ANY INCIDENTAL OR CONSEQUENTIAL DAMAGES FOR BREACH OF ANY EXPRESS OR IMPLIED WARRANTY ON THIS PRODUCT. EXCEPT TO THE EXTENT PROHIBITED BY LAW, THIS WARRANTY IS EXCLUSIVE AND IN LIEU OF ALL OTHER EXPRESS AND IMPLIED WARRANTIES WHATSOEVER, INCLUDING BUT NOT LIMITED TO, THE WARRANTY OF MERCHANTABILITY AND FITNESS FOR A PRACTICAL PURPOSE.

Some states do not allow the exclusion or limitation of incidental or consequential damages or implied warranties so the above exclusions may not apply to you. This Warranty gives you specific legal rights, and you may have other rights, which vary from state to state.

---

**WARRANTY OUTSIDE THE UNITED STATES AND CANADA**

---

The Warranty on this product if it is sold to a consumer outside of the United States or Canada shall comply with applicable law and shall be the sole responsibility of the distributor that supplied this product. To obtain any applicable warranty service, please contact the dealer from which you purchased this product, or the distributor that supplied this product.

THX and Ultra2 are trademarks or registered trademarks of THX LTD. All rights reserved.

# THX ULTRA2 LOUDSPEAKERS

Cut along dotted line and mail.

For multiple speaker purchases, please fill out only one warranty card.

Name: \_\_\_\_\_

Street Address: \_\_\_\_\_

City/State/Zip: \_\_\_\_\_

Home Phone: \_\_\_\_\_

Work Phone: \_\_\_\_\_

E-mail Address: \_\_\_\_\_

Would you like to receive the latest product updates and news via e-mail?  Yes  No

Product Purchase

Model and serial number must be included to honor your warranty card. For multiple speaker purchases, please fill out only one warranty card.

Model \_\_\_\_\_ Serial Number \_\_\_\_\_

Model \_\_\_\_\_ Serial Number \_\_\_\_\_

Model \_\_\_\_\_ Serial Number \_\_\_\_\_

Model \_\_\_\_\_ Serial Number \_\_\_\_\_

Model \_\_\_\_\_ Serial Number \_\_\_\_\_

Model \_\_\_\_\_ Serial Number \_\_\_\_\_

What store did you purchase your Klipsch products from?

Store Name: \_\_\_\_\_

State: \_\_\_\_\_

How did you hear about Klipsch?  Audio/Home Theater Magazine  Other Magazine  TV  Radio  Newspaper  
 Trade Show  Friend  Retail Dealer  Direct Mail  Website  Web Forum

Have you purchased Klipsch products before?  Yes  No

If yes, what products?

Product Name(s): \_\_\_\_\_

When do you hope to purchase additional loudspeakers?  6 mos. – 1 yr.  1–2 yrs.

How likely are you to consider Klipsch products for your upcoming purchases?  Very likely  Somewhat likely  
 Doubtful

If doubtful, why?  Don't carry product I'm looking for  Too expensive  Klipsch dealer too far away  Other

Please tell us about you!

Married  Single  Student  Male  Female

Age:  15-17  18-24  25-35  36-45  46-55  55-64  65+

Annual Household Income:  Under \$25,000  \$25-35,000  \$35-50,000  \$75-100,000  \$100,000+



3502 Woodview Trace, Suite 200  
Indianapolis, Indiana 46268  
1·800·KLIPSCH • [www.klipsch.com](http://www.klipsch.com)

Make sure you return your warranty card so that we may keep you up-to-date on new Klipsch products and promotions. As always, if you have any questions, contact your local authorized Klipsch dealer.

For your records:

Model \_\_\_\_\_

Serial Number \_\_\_\_\_

Date Purchased \_\_\_\_\_

Dealer Name \_\_\_\_\_

Klipsch Audio Technologies  
3502 Woodview Trace, Suite 200  
Indianapolis, IN 46268

Place  
FIRST CLASS  
Postage  
Stamp Here